

**MS300**

## BestPack™ Mobile Stretch Wrapper Semi-Automatic

The BestPack MS300 mobile stretch wrapper is designed to be a portable and efficient aid for packaging in your facility.

Perfect for wrapping pallets in different or changing locations of your warehouse, manufacturing facility, or distribution center. The BestPack MS300 mobile stretch wrapper is the ideal solution for environments where flexibility and efficiency in packaging are essential.

**CBM Systems BestPack™ Mobile Wrapper**



### See what the MS300 can do for you!

1. Film Pre-Stretch of up to 300% & 230%.

2. Wrap pallets of nearly all sizes, including irregular, large, and heavy loads.

3. Forklift Free Operation - push button controls allow you to move the machine anywhere!



#### Plug while you're away – Always charged when you need it!

On one full charge, this machine can wrap up to 300 pallets. Just set your wrap settings and let it do the work.



#### Improve load integrity and reduce shipping damage

Consistent performance and excellent load stability during transport keeps your load tightly secured more effectively than hand-wrapping.



#### Lower overall cost per load

Get the job done faster and waste less stretch wrap when switching to a BestPack™ mobile stretch wrapper.

Contact us for more information

+1 (909) 670-8888 | [sales@cbmsystem.com](mailto:sales@cbmsystem.com) | [www.cbmsystem.com](http://www.cbmsystem.com)

© 2025 CBM Systems, Inc. and BestPack Packaging Systems. All rights reserved. 250131

## MS300 Specifications

Performance	
Traveling Speed	295 ft./min
Max. Pallet Size	∞
Min. Pallet Size	24" L x 24" W
Max Wrapping Height	95" H
Film Delivery	
Film Pre-Stretch Ratio (%)	300% & 230%, two-step changeable with handle (250% & 200% optional)
Film Tension	Adjustable
Film Carriage Speed	Adjustable
Film Capacity	10" diam x 20" W
Height Sensor	Standard
Machine / Shipping Data	
Machine Size	63" L x 49" W x 110" H
Packing Size	102" L x 41" W x 53" H
Machine Net Weight	794 lbs
Noise	≤75 dB(A)
Power Requirements	110V, 60 Hz
Operating Temperature	0°C - 40°C
Accessory (Optional)	Remote Control

## Machine Footprint

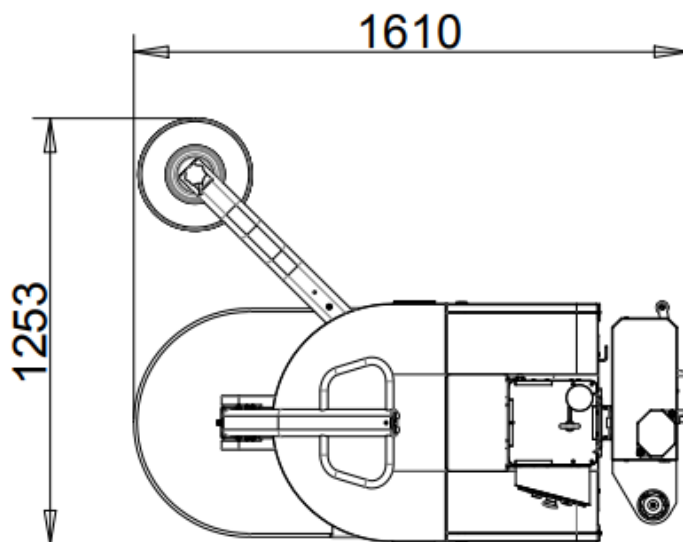
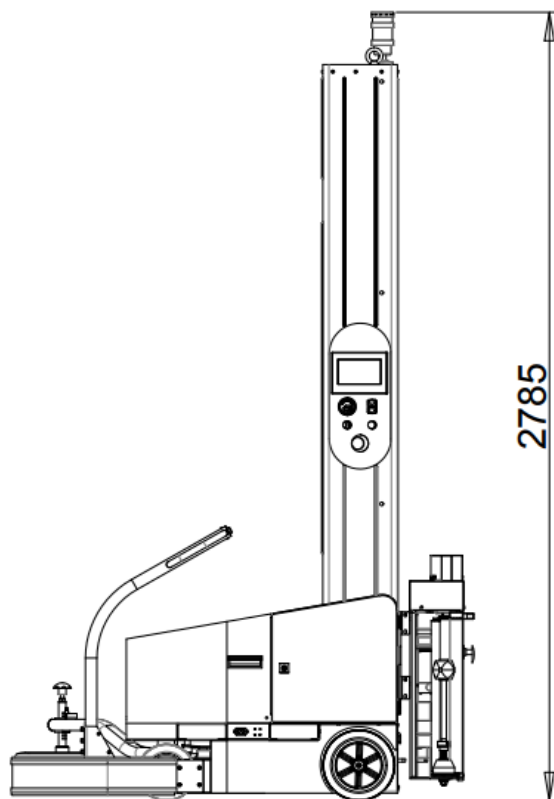

### Make wrapping as easy as 1... 2... 3...!

*Position your wrapper, hit start, and let the MS300 take care of the rest!*

- Keep your products secure and stable as your pallet stays in place while being wrapped.
- Adjustable wrap settings to meet any specific needs and ensure optimal protection.
- Stage your pallets and wrap them without the need for a forklift.
- Pre-stretch film up to 300%.
- Compact and space-efficient compared to large stationary rotary wrappers.
- Touchscreen Interface - Simple to use and saves up to 10 wrap settings!

Specifications subject to change without notice.  
<sup>1</sup> Wrap speeds may vary depending on load configuration.

Contact us for more information

**+1 (909) 670-8888 | sales@cbmsystem.com | www.cbmsystem.com**

© 2025 CBM Systems, Inc. and BestPack Packaging Systems. All rights reserved. 250131