

WH-25/30S

STAINLESS HAND PALLET TRUCK

- ◆ All metal parts made completely stainlesssteel, including hydraulic pump, fork frame, handle and so on.
- ◆ Ideal transport aid for application in damp or harsh environments such as meat or fish processing plants, dairies, pharmaceutical and chemical industry.
- ◆ Specially designed for applications where hygiene is of utmost importance.

FEATURE				
1.1	Capacity	kg	2500/3000	
1.2	Pump type		Stainless steel Pump	
WHEEL				
2.1	Wheel type		Nylon	
2.2	Size of steering wheel	ΦD mm	200x50	180x50
2.3	Size of load wheel(single)	Φd mm	80x93	74x93
2.4	Size of load wheel(tandem)	Φd mm	80x70	74x70
DIMENSION				
3.1	Min. fork height	H1 mm	85	75
3.2	Max.fork height	H mm	200	190
3.3	Lifting height	h mm	115	
3.4	Size of fork	S mm	160x60	
3.5	Fork overall width	W mm	540/685	
3.6	Fork length	L mm	1150/1220	
3.7	Weight	kg	72-82	
3.8	Remark		All Stainless 304 Option for Stainless 316	

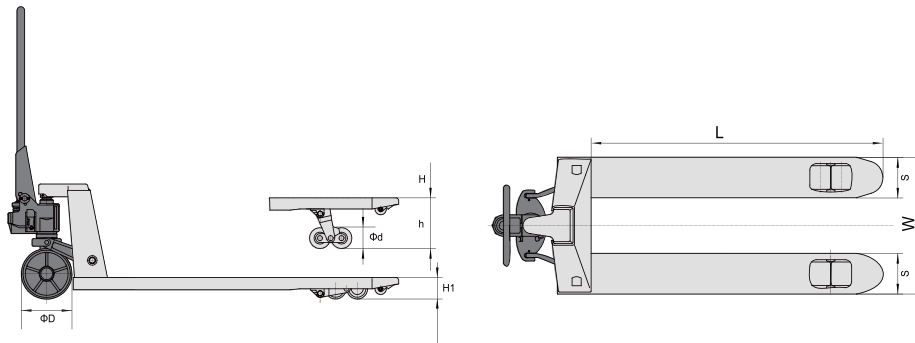

Contact us for more information

+1 (909) 670-8888 | sales@cbmsystem.com | www.cbmsystem.com

© 2026 CBM Systems, Inc. and BestPack Packaging Systems. All rights reserved. 250131

Hand Pallet Truck

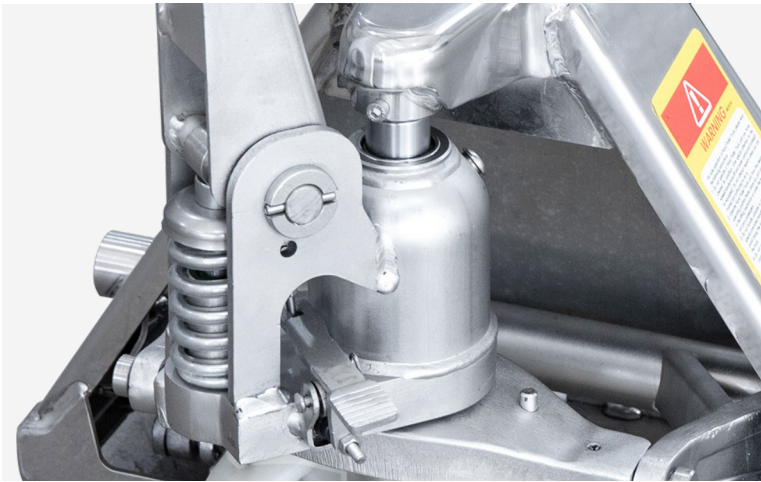

- ◆ With pressure relief valve and overload valve to prevent pump damages when loads exceeds weight limits.



- ◆ Nylon fork rollers as standard option for damp or harsh environments applications.



75mm min. fork height



85mm min. fork height

- ◆ The enclosed fork tips (for Aisi304 stainless truck only) ensure there is no dead corner where corrosive spatters remains and damages the truck.



Contact us for more information

+1 (909) 670-8888 | sales@cbmsystem.com | www.cbmsystem.com

© 2026 CBM Systems, Inc. and BestPack Packaging Systems. All rights reserved. 250131